

Raincap



discom

EXHAUST TECHNOLOGY

Solutions for a **better world**

# Raincap

The raincap provides your motor with optimum protection in our humid climate. It protects your engine against damage caused by rain, hail or snow. On top of that, our raincaps are particularly quiet due to their design.

A raincap that is very easy and quick to install and that provides maximum protection at minimum cost and requires no maintenance. Because of the high demand, almost all raincaps are available from stock and can be delivered to you within a few days.

## ***Assembly***

It is important that the cap is free to open fully. If the penetration is too large or if the gas velocity is too low, it will have a negative effect on the operation.

If you keep the top of the mounting ring flush with your exhaust pipe, the special design of the cap creates a quiet end result.

## ***Quality and safety***

Our working method, from design to delivery, follows procedures that comply with and are certified in accordance with the ISO 9001 standard. A CE marking is not required for these products as they are a component intended for installation. However in the description of your final product you will have to indicate any potential dangers, for example risk of burns.

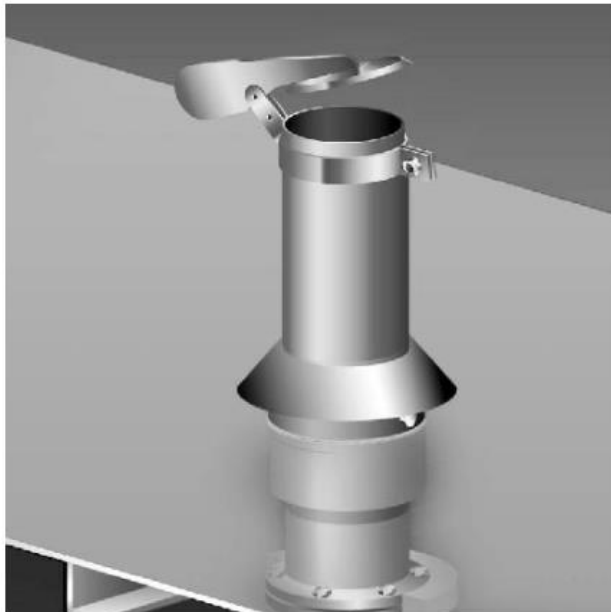

### Technical data

- Completely made of stainless steel
- Low noise
- Balanced
- Maintenance free
- Durable
- Easy to assemble

### Dimensions

Model	ND		A (mm)	B (mm)	C (mm)	D (mm)
	(Nominal penetration)	(ext. pipe diameter)				
RCS	040	1 ½"	48.3	62	138	82
RCS	050	2"	60.3	68	143	82
RCS	065	2 ½"	76.2	76	151	82
RCS	080	3"	88.9	83	158	87
RCS	100	4"	114.3	95	170	87
RCS	125	5"	139.7	108	272	97
RCS	150	6"	168.3	123	297	97
RCS	200	8"	219.1	148	310	97
RCS	250	10"	273.0	174	345	97
RCD	250	10"	273.0	165	280	110
RCD	300	12"	323.9	180	290	125
RCD	350	14"	355.6	200	300	125
RCD	400	16"	406.4	215	385	125
RCD	450	18"	457.2	235	395	120
RCD	500	20"	508.0	275	405	120

